

CROSS JOINT MILLING MACHINE

KSF-2A



Window & door
manufacturers

Furniture & kitchen
producers

Suppliers of
aluminum profiles



Watch on YouTube

STEGHERR CROSS JOINT MILLING MACHINES: GLOBAL LEADERS FOR GOOD REASON



The Cross Joint Milling Machine KSF-2A is a special milling machine for the efficient manufacture of cross joints, equipped with an electronic positioning unit and a programmable machine control.

The millings for the cross joint are done fully automatically by two pairs of milling units working in opposite directions. This operating method ensures that even profiled bars are milled absolutely tear-free on the view side of the joint.

FEATURES

- Tear-free cutting of profiled bars
- Completely in-house developed and programmed machine software
- Easy to use
- Low investment

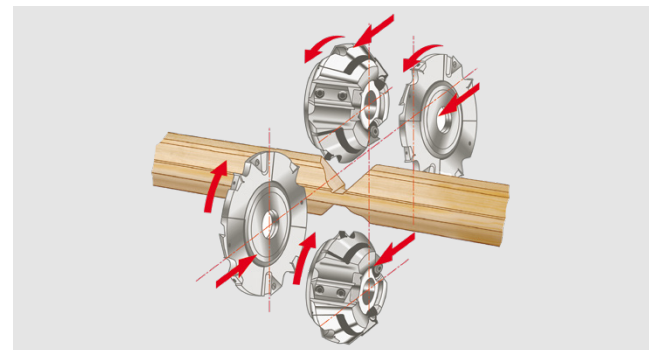

Intuitive interface

Very easy programming over a touch screen with graphical user interface. The operation is user-oriented and intuitive with clear icons. The machine operator can store up to 500 individual programs.

